

No.	DESCRIPTION	DATE	SIGN

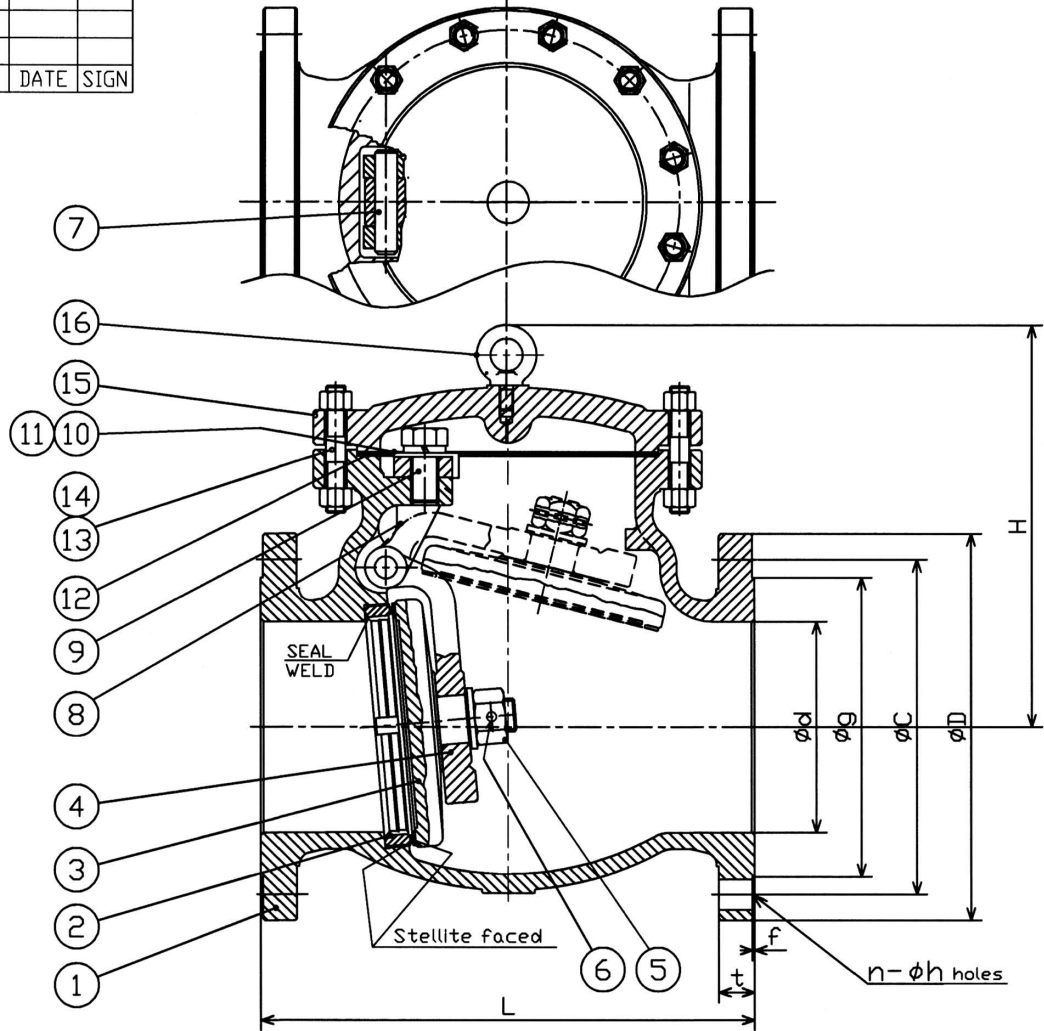

Unit : mm

SIZE (A)	d	L	JIS B 2220 20K FLANGE						H	WGT (kg)	REMARK
			D	C	g	t	f	n-φh			
50	51	267	155	120	96	18	2	8-19	144	20	
65	64	292	175	140	116	20	2	8-19	162	35	
80	76	318	200	160	132	22	2	8-23	210	40	
100	102	356	225	185	160	24	2	8-23	260	61	
125	127	400	270	225	195	26	2	8-25	280	80	
150	152	444	305	260	230	28	2	12-25	326	130	
200	203	533	350	305	275	30	2	12-25	378	190	
250	254	622	430	380	345	34	2	12-27	435	296	
300	305	711	480	430	395	36	3	16-27	521	450	

Marking (EX.)

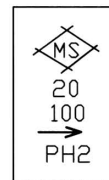

Nominal Pressure	JIS 20K
Test Press. of Shell	5.1 MPa
Test Press. of Seat	3.74 MPa
Max. Working Temp.	425 °C
Apply Medium	Water Steam Oil
Design and Manufacture Standard	
Design and Manufacture Standard	API 6D
Inspection and Test Standard	JIS B 2003
Face to Face Dimension	JIS B2002
Flange Dimension	JIS B 2220

16	EYE BOLT	Carbon S.	1	
15	BONNET	SCPH2	1	
14	BONNET NUT	A194-2H		
13	BONNET BOLT	A193-B7		
12	GASKET	Graphite	1	Spiral Wound
11	TONGUE WASHER	SUS304		
10	SPRING WASHER	SUS304		
9	BOLT	SUS304		
8	YOKE	A216-WCB	1	
7	ARM PIN	A182-F6a	1	
6	STEEL WIRE	SUS304	1	
5	NUT	A194 2H	1	
4	ARM	A216-WCB	1	
3	DISC	SCPH2	1	Stellite Faced
2	SEAT RING	A105	1	Stellite Faced
1	BODY	SCPH2	1	

PART NO.	PART NAME	MATERIAL	Q'TY	REMARK
CAST STEEL JIS 20K FLANGED END				
SCALE				
SWING CHECK VALVE				
SIZE 50A-300A				
APPROVED BY	CHECKED BY	DRAWN BY	DRAWING No.	
F.Makimura	M.Toyama	H.Hosoi	HCH010378	
NOV.16.2008	NOV.16.2008	NOV.16.2008		
MAKIMURA MFG CO LTD HIKONE SHIGA JAPAN				