

No.	DESCRIPTION	DATE	SIGN

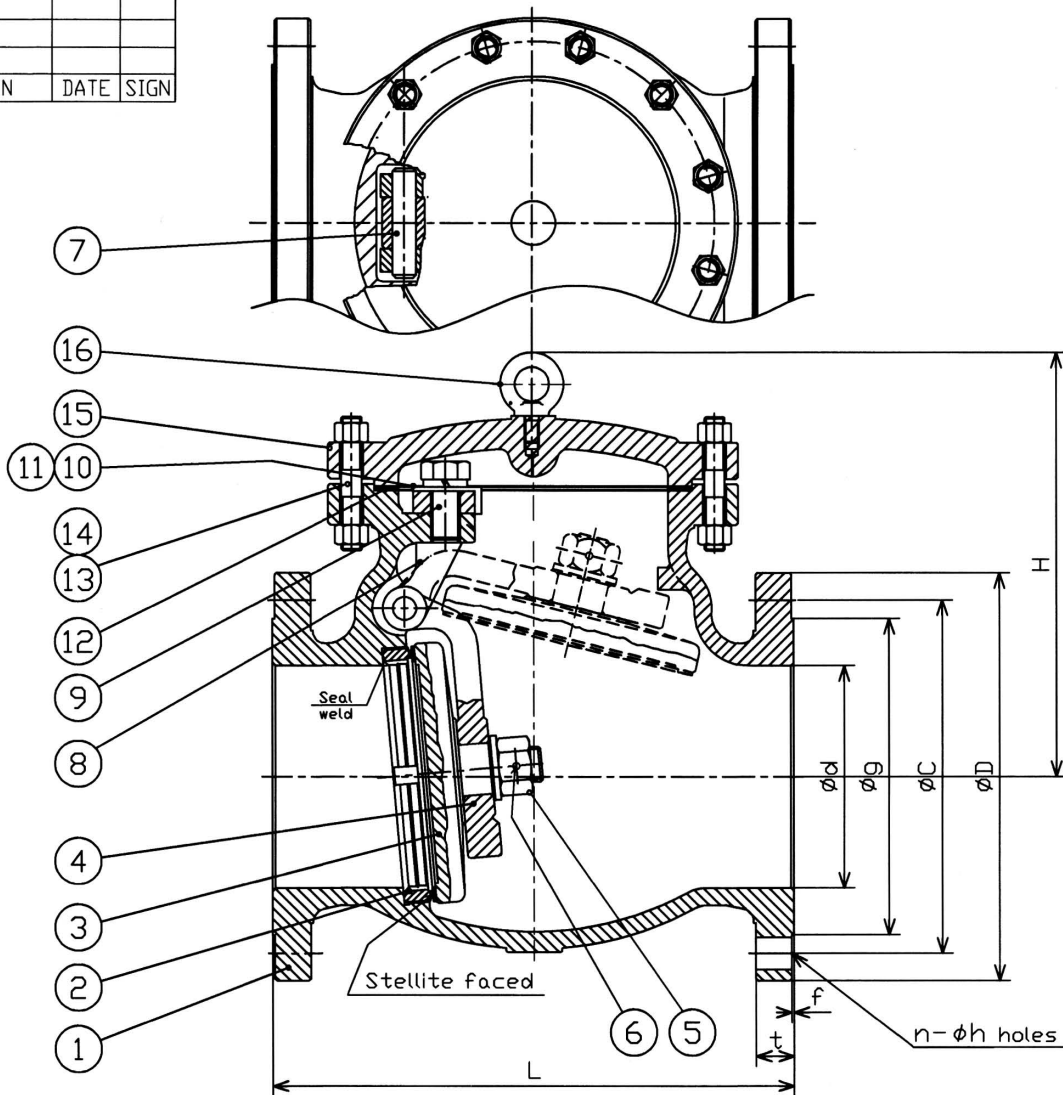

Unit : mm

SIZE (A)	d	L	JIS B 2220 10K FLANGE						H	WGT (kg)	REMARK
			D	C	g	t	f	n-φh			
50	51	203	155	120	96	16	2	4-19	132	15	
65	64	216	175	140	116	18	2	4-19	147	20	
80	76	241	185	150	126	18	2	8-19	176	27	
100	102	292	210	175	151	18	2	8-19	198	45	
125	127	330	250	210	182	20	2	8-23	255	58	
150	152	356	280	240	212	22	2	8-23	290	69	
200	203	495	330	290	262	22	2	12-23	340	131	
250	254	622	400	355	324	24	2	12-25	408	219	
300	305	698	445	400	368	24	3	16-25	495	321	

Marking (EX)

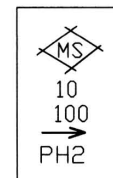

Nominal Pressure	JIS 10K
Test Press. of Shell	2.1 MPa
Test Press. of Seat	1.54 MPa
Max. Working Temp.	300 °C
Apply Medium	Water Steam Oil
Design and Manufacture Standard	
Design and Manufacture Standard	API 6D
Inspection and Test Standard	JIS B 2003
Face to Face Dimension	JIS B2002
Flange Dimension	JIS B 2220

16	EYE BOLT	Carbon S.	1	
15	BONNET	SCPH2	1	
14	BONNET NUT	A194-2H		
13	BONNET BOLT	A193-B7		
12	GASKET	Graphite	1	Spiral Wond
11	TONGUE WASHER	SUS304		
10	SPRING WASHER	SUS304		
9	BOLT	SUS304		
8	YOKE	A216-WCB	1	
7	ARM PIN	A182-F6a	1	
6	STEEL WIRE	SUS304	1	
5	NUT	A194 2H	1	
4	ARM	A216-WCB	1	
3	DISC	SCPH2	1	13%Cr. Steel Faced
2	SEAT RING	A105	1	Stellite Faced
1	BODY	SCPH2	1	

PART NO.	PART NAME	MATERIAL	Q'TY	REMARK
CAST STEEL JIS 10K FLANGED				SCALE
SWING CHECK VALVE				
SIZE 50A-300A				
APPROVED BY	CHECKED BY	DRAWN BY	DRAWING No.	
F.Makimura	M.Toyama	H.Hosoi	HCH010385-1	
NOV.16.2008	NOV.16.2008	NOV.16.2008		
MAKIMURA MFG CO LTD HIKONE SHIGA JAPAN				